

PULL BOXES SHALL BE PLACED BEHIND THE SIDEWALK OR IN THE PLANTER AREA WHENEVER POSSIBLE. TRAFFIC RATED BOXES AND COVERS SHALL BE USED IF A PULL BOX MUST BE INSTALLED IN THE SIDEWALK OR DRIVEWAY.

NOTES:

1. STEEL COVER SHALL HAVE EMBOSSED NON-SKID PATTERN.
2. STEEL REINFORCING SHALL BE AS REGULARLY USED IN THE STANDARD PRODUCTS OF THE RESPECTIVE MANUFACTURER.
3. PULL BOX COVERS SHALL BE MARKED AS DESCRIBED IN NOTE 5 ON STANDARD DRAWING SL-4. MARKING SHALL BE APPLIED TO EACH COVER PRIOR TO GALVANIZING BY BEAD WELDING THE LETTERS ON THE COVERS. THE LETTERS SHALL BE RAISED AT LEAST 3/32 INCH.
4. BONDING JUMPER FOR COVER SHALL BE A MIN. OF 36" LONG. WHEN NON-METALLIC CONDUIT IS USED, THE BONDING JUMPER FOR THE COVER SHALL BE SPLICED TO THE BOND WIRE IN THE CONDUITS. WHEN THE USE OF METALLIC CONDUIT IS SPECIFIED ON THE PLANS OR IN THE SPECIAL PROVISIONS, THE BONDING JUMPER FOR THE COVER SHALL BE CONNECTED TO THE CONDUIT GROUND BUSHING, AND THE CONDUITS SHALL BE BONDED TOGETHER WITH GROUND BUSHINGS AND A BONDING JUMPER.
5. CONDUITS SHALL ENTER AT BOTTOM OF PULL BOX AS SHOWN IN THE DRAWING.
6. PULL BOXES FOR STREET LIGHTING, UPON COMPLETION OF BURN TEST, SHALL BE FILLED WITH CONTROLLED DENSITY BACKFILL PER CITY OF ELK GROVE CONSTRUCTION SPECIFICATIONS SECTION 50-15. A 5 MIL. PLASTIC SHEET SHALL COVER THE CONDUITS/WIRES PRIOR TO POURING OF BACKFILL, TO A DEPTH OF TWO (2) INCHES OVER THE CONDUITS.

PULL BOX No.	REINFORCED CONCRETE BOX					
	MIN.** THICKNESS	MIN. DEPTH BOX AND EXTENSION	LO	WO	L	W
3-1/2	1"	NO EXTENSION	20"	14"	15-1/2"±	10"±
5	1"	22"	28"	18"	23"±	13-1/2"±
5A	1"	22"	25-1/4"	15-3/4"	21"±	10-1/2"±

** EXCLUDING CONDUIT WEB

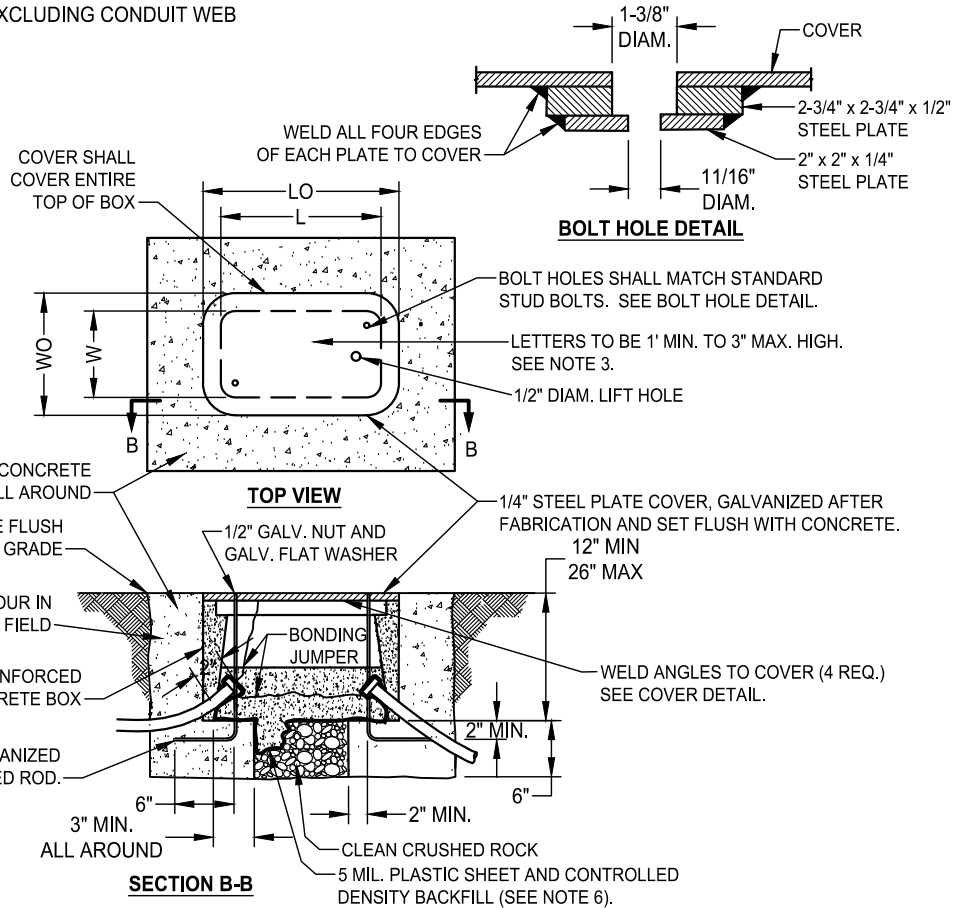
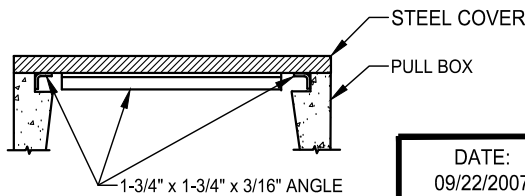
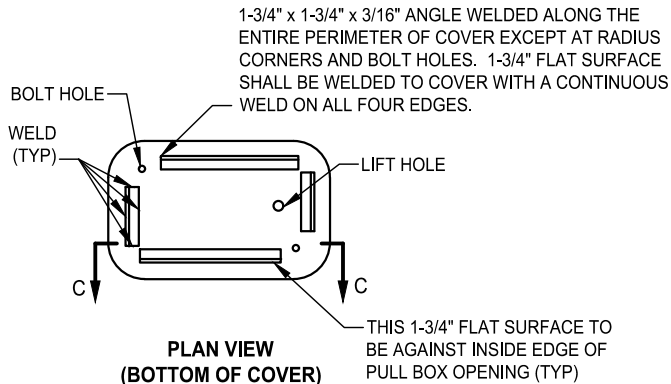

DATE: 09/22/2007		NOT TO SCALE	
REVISION	BY	APPROVED	DATE

CITY OF ELK GROVE - PUBLIC WORKS

TRAFFIC-RATED PULL BOX

APPROVED BY:
Robert Murdoch
CITY ENGINEER

10/24/2018
DATE

DRAWING NUMBER
SL - 5